



JETBLACK cycling™

MM Mag TRAINER

www.jetblackcycling.com
info@jetblackcycling.com

Code: JBT-M1

Please read the following directions thoroughly before use.

CAUTION

- This trainer is intended for single-rider bicycles only.
- Read and follow all instructions.
- Before beginning each workout, be sure the bicycle is securely attached to the trainer.
- Resistance unit can become hot enough to cause burns. Do not touch resistance unit during use and for some period after use until it has had sufficient time to cool.
- Keep children and pets away from the trainer during use.
- Before you start any exercise program you should consult a physician.

WARNING

Read and follow all instructions concerning installation of the bicycle on the trainer. Failure to securely attach the bicycle to the trainer could result in serious injury to the rider or bystanders.

BICYCLE MOUNTING INSTRUCTIONS

1. Prepare the trainer for bicycle mounting by rotating the large adjustment knobs counter clockwise until the clamp cones are wide enough to accommodate the bicycle's rear wheel axle/skewer mechanism. Rotate the smaller locking ring counter-clockwise, moving them outward away from the trainer frame. **Diagram 1**
2. Turn the roller adjustment knob counter-clockwise a few rotations so the roller is past vertical to allow for clearance of the rear tire while mounting. **Diagram 2**
3. Replace the bicycle's rear wheel quick release (QR) skewer with the one provided with the trainer. See bicycle owner's manual for instructions on how to properly adjust the QR skewer. Make sure the skewer is tight and that your wheel is aligned properly on the bicycle.
4. Carefully lift your bike into position, aligning the rear QR skewer with the axle clamp cones. While holding the bicycle steady, slide the right side QR skewer nut into the axle clamp cone. **Diagram 3**

Using the adjustment knobs, tighten the clamp cones until they come into contact with the bicycle's QR skewer ends. Make sure that the QR skewer aligns with the notch in the clamp cones. Rotate the clamp cone cup as necessary to centre the bicycle's rear wheel over the centre of the roller on the roller assembly.

After contact is made, tighten by turning the adjustment knobs until the bike is securely held in the frame – an additional 4-6 complete turns of the handle.

Rotate the locking ring clockwise until it is snug against the trainer frame. Check that the bicycle is secure by pushing or pulling on the bicycle's top tube or seat. **Diagram 4**

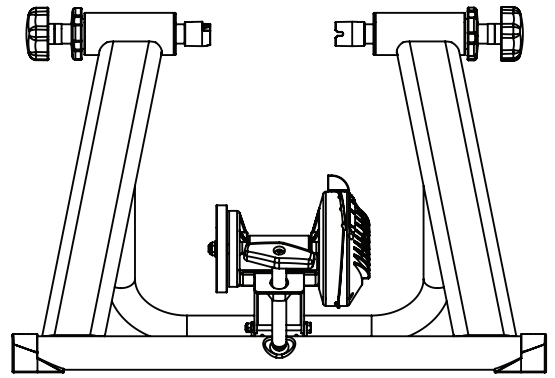

Diagram 1

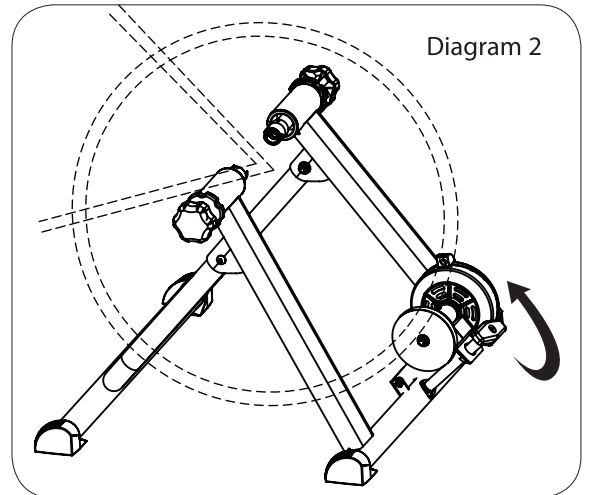
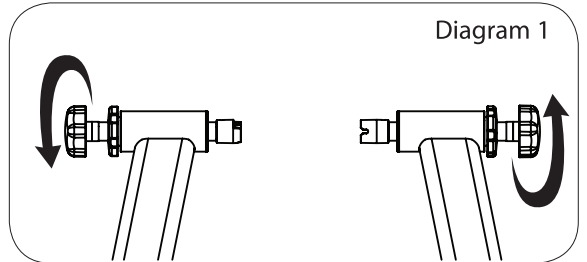

Diagram 2

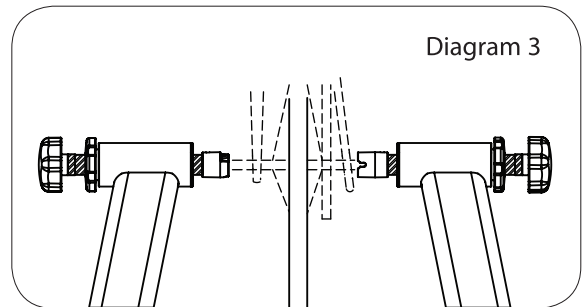

Diagram 3

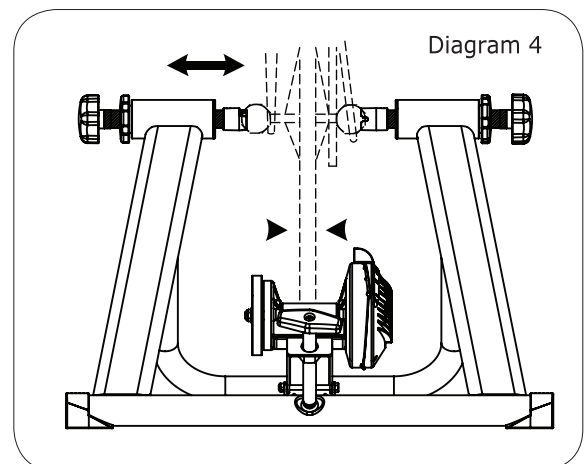

Diagram 4



JETBLACK cycling™

MM Mag TRAINER

USING YOUR TRAINER

1. Tighten the roller adjustment knob by turning it clockwise until the resistance unit roller assembly contacts the rear tire. See Diagram 5. Then tighten the knob an additional 1½ to 2 full turns. The roller needs to provide only enough pressure to prevent the rear tire from slipping while in use. Over tightening the knob bolt may cause premature tire wear.
2. Keep in mind that riding on an indoor trainer will cause your rear tire to wear more quickly than it would on the road. The tips below will help minimize tire wear.
 - a) Allowing the tire to slip against the roller will accelerate tire wear. If you notice the tire slipping regularly during use, tighten the knob by additional ¼ turn as necessary to reduce slipping.
 - b) Try to apply power more evenly when accelerating and pedal with a smoother stroke.
 - c) Use a smooth tread tire at least 23mm in width and maintain the maximum recommended inflation pressure for your tire.
3. To make your indoor workout as quiet as possible, set the trainer on a JetBlack Trainer Mat and use a rear tire with a smooth tread pattern. Once attached, the bicycle slopes downward slightly. To level, use the optional JetBlack Riser Block under the front tire.
4. This trainer has 5 levels of resistance to help keep variety in your workout program. To change the level, move the orange lever up or down as required. Level 1 is the least (easiest) level of resistance, and level 5 being the hardest. Changing gears on your bike will also have an effect on your exertion levels.

BICYCLE REMOVAL

1. Loosen the roller adjustment knob so the resistance unit is as close to the floor as possible.
2. While supporting the bicycle, loosen the left side axle support cup by turning the adjustment knob counter-clockwise, until the rear wheel axle is free of the support cups.
3. Note: The QR skewer provided with the trainer can be used when riding the bicycle of the trainer as well. If you choose to reinstall your bicycle's original skewer, refer to your bicycle owner's manual for instructions on properly adjusting the skewer. Before riding, ensure the quick release skewer is tight.
4. To store or transport your trainer, grasp the trainer frame by the adjustment knobs and lift. Fold the legs together, and the trainer is ready for transport or storage. Be careful when folding the legs to avoid pinching your fingers.

